

STUDER – Supplier of Turnkey Systems

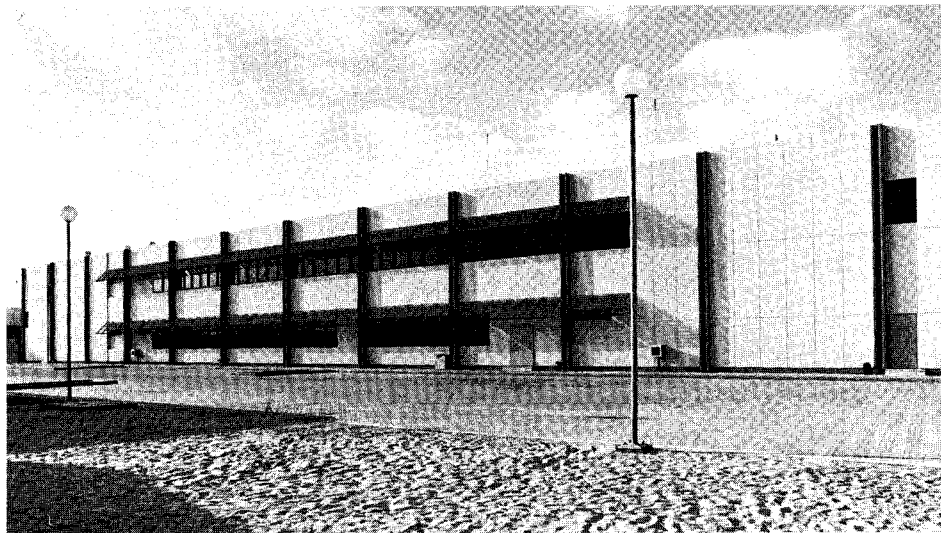

It does not happen every year that an interesting and large project such as the Broadcasting House in Abu Dhabi (described in detail in a special color issue of SWISS SOUND) can be realized.

Even though such projects do not come about frequently, the fact remains that on account of the wide spectrum of professional audio equipment we offer, our company is ideally suited to satisfy the most diverse requirements as far as complete systems are concerned. This requires the input of special services which had to be developed over the years and which need gradual expansion. There is the team of specialists looking after consulting, installing, training and putting complete systems into operation. Its members being recruited from our own staff, a most fundamental knowledge of our products is consequently offered. Getting involved in a project right from the start, close collaboration with design and production departments of mixing consoles enables the team to take even special requests into consideration a customer may have with complex systems during an installation phase.

There is an ever increasing need for closer cooperation with manufacturers of television equipment to ensure exact interfacing with their systems. This may be of importance when mixing consoles or tape recorders have to be installed in television OB-Vans or, when fully integrated systems are to be realized. We

also look after the procurement and installation of specialized equipment incorporated in systems of other manufacture.

And we will always attempt to have a system ready for operation before it leaves the factory. All essential interconnections will be plug-in types so as to keep time and expenses low when installing and preparing equipment on site, at the same time guaranteeing faultless operation from the very beginning.

During the coming months, we will present other interesting projects we have realized, and will also acquaint our readers with synchronizing systems.

Eugen E. Spörri

SWISS 13 SOUND

Read in this issue:	page
● Switching Action	1
● Speed Reader	3
● OB-Van	5
● Sales Manager Worldwide	6-7
● Perfection in Texas	8
● Fast Broadcasting	9
● Assembling in India	11
● Abu Dhabi Special	Enclosure

A820-High-Efficiency Reel Motor Controller

Switching Action instead of Heat

One of the underlying objectives in technical research is to improve the efficiency of energy conversion processes. Organic systems have long been optimized in this respect. They save energy because nature intrinsically minimizes losses. In technical systems, most of the lost energy is dissipated heat, a phenomenon which causes additional cooling problems. For this reason, a new approach was adopted in the design of the controller for the reel motor in the A820 product line. A servoamplifier with pulse width modulation (PWM) was developed to keep losses as low as possible.

Basically, there are two different ways to control reel motors: with analog controllers or digital controllers with electronic switches. This distinction does not apply to servocontrol circuits but instead to the power amplifier from which the motor draws its energy.

The conventional way to control a DC reel motor can be explained on the basis of the motor used in the A800. Figure 1 shows a simplified circuit diagram of the analog power amplifier: two identical regulating circuits with a positive and negative supply voltages which correspond to the two rotational directions of the motor are needed. Transistors Q₁, Q₂ and Q₃ as well as Q₄, Q₅ and Q₆ operate as variable longitudinal resistance and regulate the current I_M in the motor.

The disadvantage of this circuit is the necessity of having two separate power supply units. However, there is a more serious disadvantage in the operating mode, particularly in the record and playback functions used most: if the motors need only supply minimal moments at low speed (PLAY), only a small voltage should be applied across the motors, i.e. the difference to the supply voltage must be removed as a voltage drop in the electronic longitudinal resistances. The result is a considerable dissipation loss which produces heat and increases consumption unnecessarily.

Switched Controller

The switched controller incorporates no actuators. Fully electronic switches

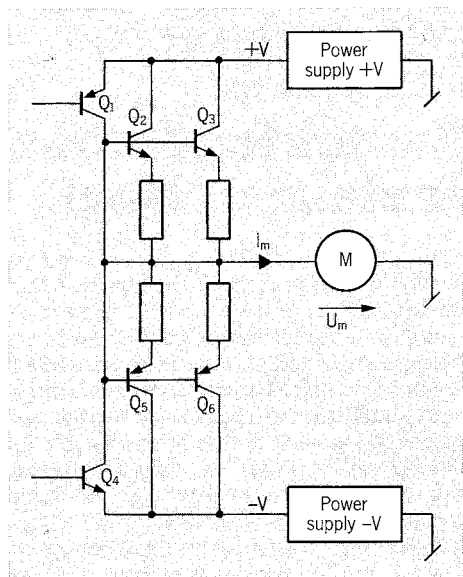

Fig. 1: Basic conception of an analog power stage.

(POWER FET: S1/S4 and S2/S3) are wired in a full-bridge configuration (Figure 2). These switches are alternately opened and closed in pairs. In contrast to an analog control setup, this configuration requires only one supply voltage to run the controlled motor forward and reverse. An explanation of the operating principle of this switched power amplifier shows that a symmetric rectangular voltage is generated at points A and B when the switches are alternately on and off during identical time windows

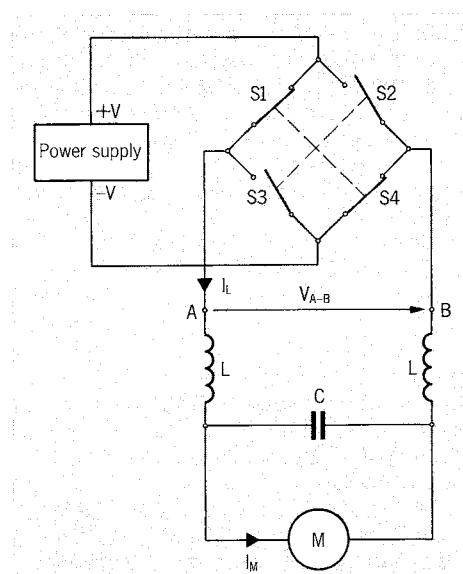

Fig. 2: Basic conception of a switched power stage.

(clock frequency 76 kHz). An average current of zero amperes flows through inductors L, i.e. the motor does not turn (Figure 3). If the rectangular voltage becomes asymmetric (unequal on and off time; Figure 4), an average DC current flows through inductor L and thus through the motor. The motor generates a corresponding moment and accelerates to start. As soon as the motor starts turning, an electromotric force EMF builds up in the winding of the disk-type motor. This EMF is polarized in opposition to the motor voltage and decreases the motor current so that - depending on the voltage - a balance occurs as a certain speed.

If the mark to space ratio is reduced again, the current flows from the motor (which now operates as a generator)

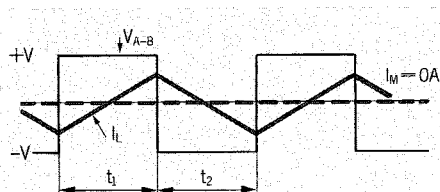

Fig. 3

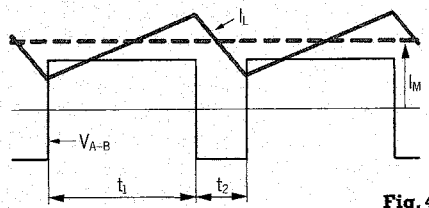

Fig. 4

back into the power supply circuit which means that energy can be recovered from the motor.

A longer duty cycle of switches S1/S4 versus S2/S3 produces a positive current in point A. A shorter switching cycle of S1/S4 invariably results in a longer closing period of S2/S3 and thus a current in B, i.e. out of A. The current through the motor can be changed in terms of magnitude and direction simply by changing the mark to space ratio.

Protective Circuit for the Switching Stage

The selected switch configuration makes it necessary to consider the cross-current (short circuit) problem which can arise if switches S1 and S3 or S2 and S4 are simultaneously closed. A cross-current primarily develops during switching transients and can be prevented by delaying the "on" cycle relative to the "off" cycle. This is done with a

network (resistance/diode) in the gate feed circuit (Figure 5). The diode blocks the current during the positive switching edge and the charge reversal of the

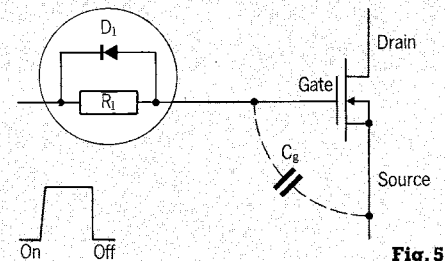

Fig. 5

gate capacitance C_g can only take place via resistor R_1 and is slower (time constant R_1/C_g) than the charge reversal which occurs in response to the "off" signal edge. For the duration of the "off" signal edge, the diode becomes conductive and assures that the gate capacitance is rapidly discharged. The resulting delay times of different durations prevent the corresponding switches from closing simultaneously.

High Efficiency Saves Energy and Eliminates Cooling Problems

Since the tape recorder is primarily operated in the play or record modes, efficiency in these modes is important. The following list compares A800 and A820 recorders which operate with identical disk-type motors:

PLAY:	Motor voltage $U_M = 3V$
	Motor current $I_M = 2A$
	Power consumption of motor $P_M = 6W$

Power consumption of final amplifier:

PT (A800) =	$(30V \times 2A) = 60W$
PT (A820) =	(measured) = 12W

Efficiency:

$$A800 = \frac{6W}{60W} \times 100\% = 10\%$$

$$A820 = \frac{6W}{12W} \times 100\% = 50\%$$

The 54 watts which are dissipated in the A800 and the 6 watts in the A820 are heat which must be extracted. Consequently, the heat sinks in the A800 are much larger and the operating temperature of the motor assemblies is higher.

In summary, the advantages of the switched servo-amplifier are as follows:

- Higher efficiency
- Only one supply voltage
- Reduced space requirements
- Energy is recovered during the braking phase

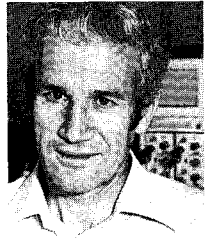

A. Schmidheiny, 47
 Graduated 1962 at the Federal Institute of Technology (ETH) as electrical engineer. For several years, development work for computer controlled test systems in the USA. Joined the WILLI STUDER group in 1977 and worked in the development of microprocessor control systems for the professional tape machines A800 and A820 as well as the realization of parallel microprocessor interfaces.

Arnold Schmidheiny

The growing trend toward studio automation and computer controlled editing systems has increased the significance of the SMPTE/EBU time code for program material. To streamline studio operations, the capability of evaluating time information must be safeguarded both for slow and high speeds.

In the studio environment, the SMPTE/EBU code has become a "de facto" international standard for electronic time coding. The time format in hours, minutes, seconds and frames was selected in response to the needs of the film and video industries. For each frame, a code value is formed with this information together with further standardized information bits and user-definable bits. The code word consists of 80 bits, of which a 16-bit wide synch word is reserved for directional identification, synchronization and data plausibility checking (Fig. 1).

The code is **biphase-modulated** to obtain a signal without a DC component. Thus, the resulting signal incorporates a signal change at the beginning of each word and additionally in the middle of each word with logic «1» (Fig. 2). If the signal still complies with EBU and SMPTE standards with respect to signal geometry (limited rise times to prevent crosstalk, minimized amplitude and time errors), it can be used in the studio as an audio signal for transmission and recording purposes.

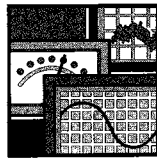

SMPTE/EBU Time Code Sampling Speed Reader

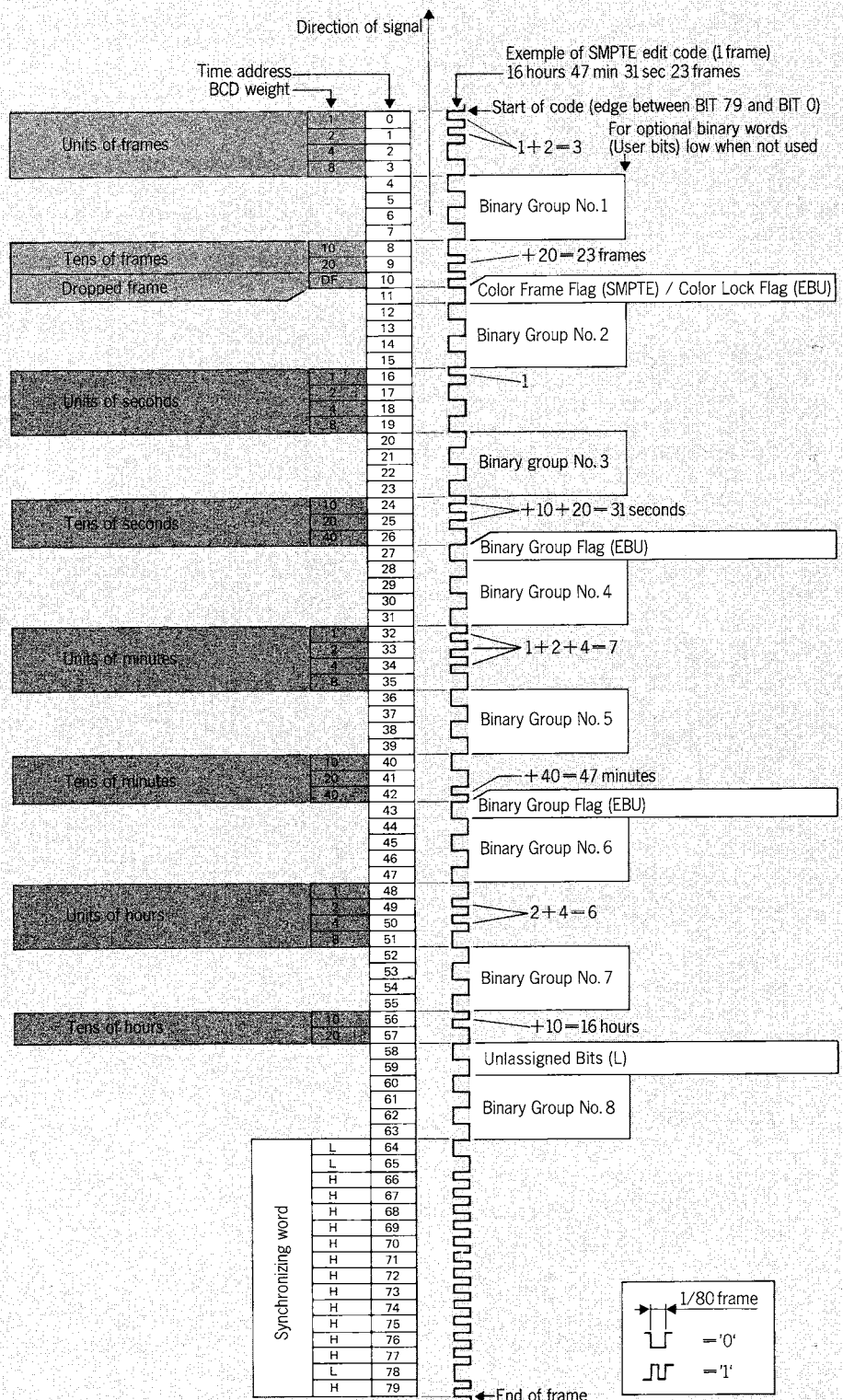

Fig. 1: Format of a SMPTE/EBU code word.

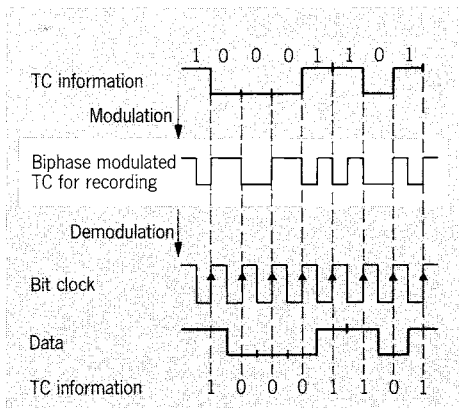

Fig. 2: Modulation and demodulation of time code.

The code sampling procedure can be subdivided into several phases (Fig. 3). On the machine side, the signal must correspond to specification both in the **record and playback** mode. To detect the code, in a range of 1/20 to 50 times nominal speed, it is necessary to reserve a signal bandwidth from 50 Hz to 100 kHz. This necessitates the use of special wide-band code sampling amplifiers.

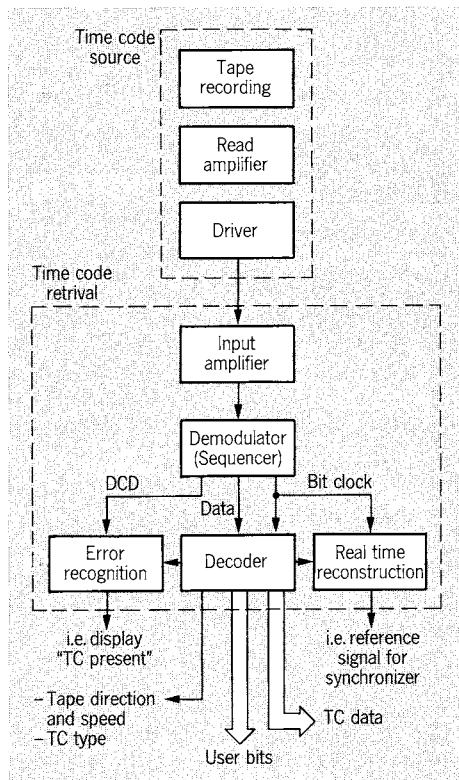

Fig. 3: Retrieval of time code.

If the code source and the sampling circuit are not accommodated in the same device, the **transmission chan-**

nel also has an influence on the quality of the signal. For noise immunity and chaining reasons, it is commonplace to adopt a transformer-symmetric transmission mode.

The **demodulator** recovers the data from the modulated signal. A bit clock is generated for synchronous processing as a reference for real-time evaluation. The DCD signal (data carrier detect) indicates whether properly modulated input data is present.

The **decoder section** must identify the code direction as well as the beginning of the 80-bit word with the aid of the synch word. The data is converted in accordance with the detected direction

Depending on the application, the decoder can handle additionally evaluation tasks and operations. Apart from the validity of the synch word, it is also possible to analyze the content of the time information for **error recognition** purposes. This plausibility test precludes illegal values (25 hours, 61 minutes: wrong time format; 0A seconds, D1 frames: illegal BCD format).

Further information such as a code type (24, 25, 30 frames per second or drop frame format), speed and direction can be forwarded to a host system (such as a synchronizer). For synchronization and control purposes, the decoder can generate real-time information at bit clock frequency. The resolution of the

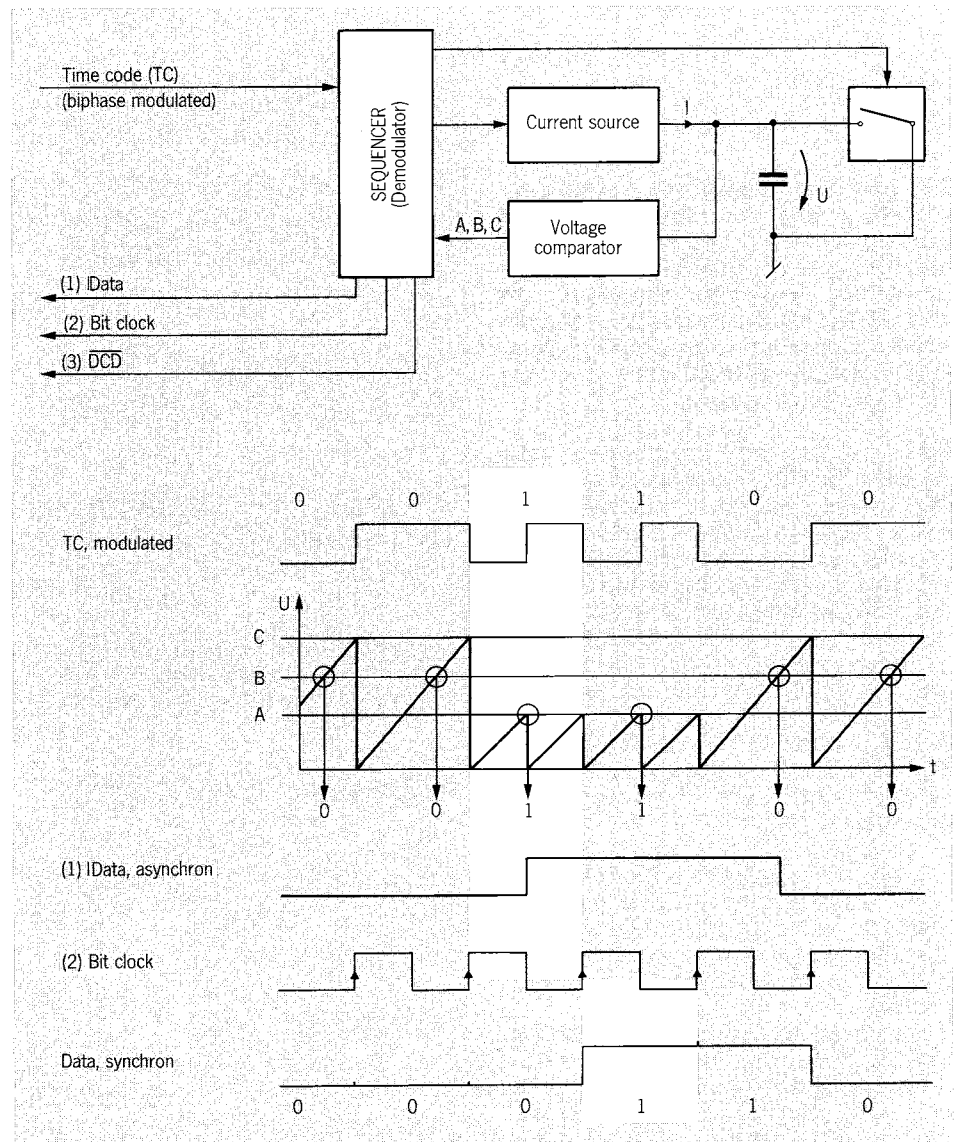

TLS 4000 Demodulator.

and then forwarded in a serial or parallel link after separation into the time and user bit information.

time code can be expanded to 1/80 bits by extrapolation. This allows editing with millisecond accuracy on time-

code-controlled electronic audio editing systems.

The technical design of the demodulator and the decoder depend on the given application. The highly integrated circuit can be used for both purposes if a pure code reading unit is needed. If the display is restricted to the nominal range, this can be a microcomputer. A custom development (such as logic array) may be necessary for a high-speed demodulator/decoder.

In the Studer **TLS 4000** synchronizer, the two function blocks are isolated from one another. While the demodulator represents an independent circuit, the decoder is part of the microcomputer. In addition to two independent SMPTE decoders, this microcomputer also processes further input signals.

The advantage of a microcomputer decoder is its ability to handle a wide variety of tasks:

In the synchronous mode, each individual frame is evaluated and intermediate values are extrapolated. In contrast, the high-speed reading mode involves periodic sampling of the code (approx. 10 values/second). Error processing can be optimized to the momentary operating mode (dropouts of a certain duration can be skipped, for example).

In contrast to the decoder which only evaluates individual code words when reading fast time codes, the demodulator must cover the entire working range. The TLS 4000 defines this working range as **1/20 to 80 times** nominal speed.

There are various technical approaches to the demodulator as well. To obtain the bit clock, the conventional PLL can be deployed in combination with a digital logic. The necessarily large trapping range in conjunction with a sufficient level of dynamic and thermal stability calls for a sophisticated analog circuit section, however (the working range from 1/20 to 80 times PLAY corresponds to a ratio of 1:1600).

A purely digital demodulator does not cause any problems associated with temperature or oscillation. A counter can handle time measurements or an evaluation of the bit period (2 half periods = «1», 1 full period = «0») over the entire range. The large range involves considerable circuit complexity which can only be reasonably implemented with highly integrated programmable ICs.

The program sequencer connected to a digitally controlled analog current

source handles the analog/digital function in the TLS 4000. This section charges a capacitor with a constant current and each code signal edge triggers a discharge. The sequencer has two functions: it controls the charging current such that level C is reached within the length of 1 bit. For evaluation purposes, it analyzes two further voltage values. If only level A is reached two times consecutively, the circuit recognizes the value «1». If level B is reached, it sig-

nalizes value «0». No temperature drift problems occur because of the closed current regulator circuit. The entire sequencer is accommodated in one single programmed element. The circuit operates impeccably in a range from 1/20 to more than 100 times nominal speed.

Kurt Schwendener

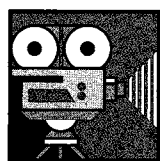

Turn-Key

OB-Van for Oman Project



Landrover 110, ready to go...



Interior audio equipment (l.t.r. below): Mains voltage supply, mixing console 269, rack with limiter jackfield, amplifier, transmitter (l.t.r. above) PR 99 tape recorders, air conditioning, loudspeakers, TV monitor, monitoring receiver.

Within the range of a large broadcast project in the Sultanate of Oman, an outside broadcasting van of special configuration was required and to be realised by STUDER. All fittings were carried out by a specialised company in England, prior to the installation of the audio part to be done by Studer International AG. The final acceptance test of the completed vehicle took place in Switzerland.

The OB-Van, specially laid out for cross-country travels, comprises a variety of equipment:

- 2 program transmitters (40 Watt, 151 MHz)
- 1 pneumatically controlled antenna mast
- Radio telephone (83 MHz)
- STUDER 269-8/4 mixing console
- 2 REVOX PR 99 tape recorders
- 2 power amplifiers for monitoring purposes in the vehicle and operation of the public address system (loudspeakers on car roof gallery)
- TV monitor
- Emergency power unit (2.8 KVA)
- Voltage stabilizer
- Converter for operation of boosting battery



End September this year, the Landrover vehicle was transported to Oman in a Jumbo Jet; its inauguration took place in practical use only two weeks later.



Introducing the Area Sales Manager
of STUDER INTERNATIONAL AG

Individual Areas of Responsibility in Europe and Overseas

Although our sales personnel is well-known to many of you, we would like to introduce the individual sales managers of our organisation, and also inform you about the areas of their responsibilities.

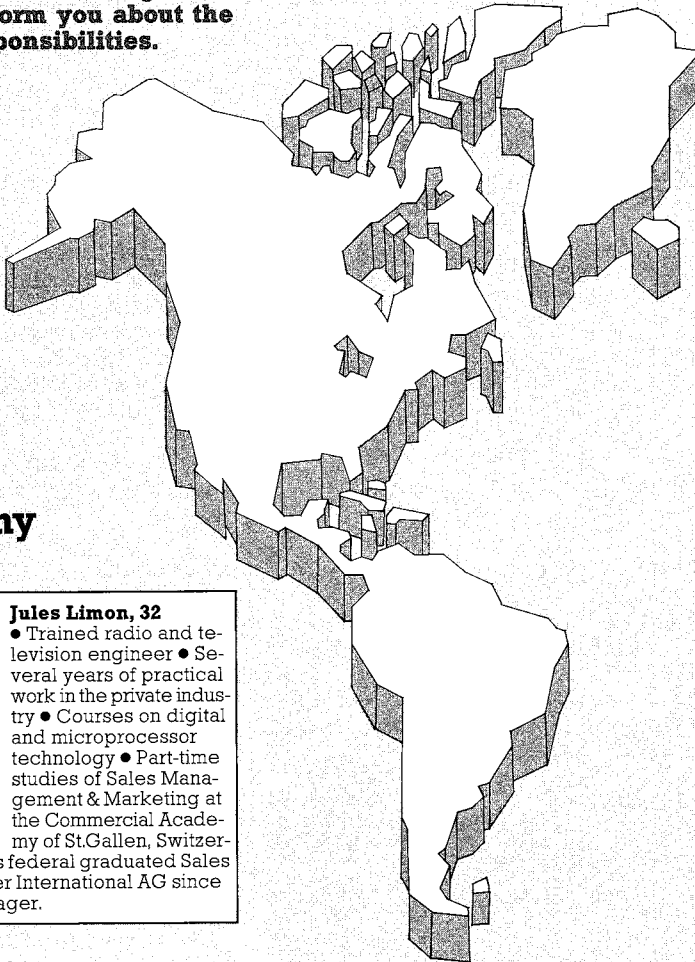

Canada USA F.R. Germany Austria



Jules Limon, 32

- Trained radio and television engineer
- Several years of practical work in the private industry
- Courses on digital and microprocessor technology
- Part-time studies of Sales Management & Marketing at the Commercial Academy of St.Gallen, Switzerland;

diploma as Swiss federal graduated Sales Manager • With Studer International AG since 1979; Area Sales Manager.

Latin America Africa



Jean-Pascal Ruch, 32

- Four years training in communication and electronics at Kudelski S.A., Cheseaux, Switzerland, followed by two years of practice at the test field department
- Joined WILLI STUDER in 1974; test field work
- Since 1976 with

Studer International AG as field service technician for French speaking areas in Europe and Africa; sales activities • 1980 for one year technical work at the service department of Studer Revox Canada Ltd., Toronto, combined with studies of the English language • Since 1981, Area Sales Manager of Studer International AG.

Western Europe

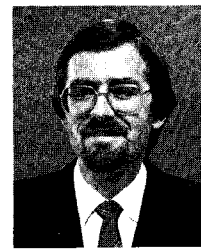

Heinz Schiess, 35

- Trained radio technician; studies at Winterthur Polytechnic School of Engineering, Diploma as an electric engineer HTL in telecommunications
- With STUDER since December 1973; worked in the laboratory of STUDER measuring instruments; for two years, field engineer at STUDER FRANCE S.a.r.l. in Paris. Two years commercial and technical work at Studer Revox Canada Ltd. in Toronto
- Courses on Management and Economics (AKAD)
- 1979-81 Area Sales Manager at Studer International AG North and Latin America, Australia and New Zealand
- For two years, project manager at WILLI STUDER AG; specially assigned to reorganize development department
- Since 1984, Area Sales Manager of Studer International AG, and editor ad interim of the STUDER REVOX magazine "SWISS SOUND".



Felix Kellermüller, 52

- Trained mechanic; four years Metal Workers School, Winterthur, Switzerland. High-school education, trained architectural draftsman
- Studies at Burgdorf, Polytechnic School of Engineering, Diploma as supervisor builder/constructor. Architekt HTL
- One year of practice in a London architecture office
- Since 1975 with Studer International AG as Sales Engineer.

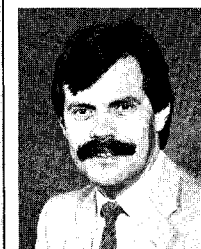

Kuno Lischer, 35

- Trained telecommunications and electronics technician; three years commercial school
- Project manager in the quality control department of a paper-manufacturing company
- Several part-time courses on marketing and sales management
- Marketing and Area Sales Manager in a large Swiss manufacturing company for electronic traffic control equipment
- With Studer International AG since November 1980, sales manager North and Latin America. Special assignment for two and a half year as administrator/coordinator at STUDER REVOX Canada Ltd., Toronto
- Since September 1985 back at Studer International AG as Sales Engineer.

Switzerland



J.-François Raoult, 31
 • After final school examination (Maturum), practical work in various test field departments of WILLI STUDER
 • 1979-81 Polytechnic School of Engineering, Winterthur; worked for one year at the documentation department of WILLI STUDER, responsible for the realization of STUDER A800/TLS 2000 manuals • 1983 Product Engineer at Studer International AG for multichannel equipment and synchronizer systems • Since mid-1985, Area Sales Manager responsible for marketing and sales of STUDER products in Switzerland.

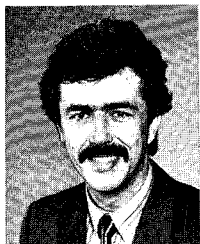

Bernhard Kohler, 36
 • Four years training in electronics and communication at Hasler AG, Berne • Joined Studer in 1969 and worked at the studio project department of the factory. Two years technical part-time studies • Worked in production of WILLI STUDER AG and became head of the test field department for individual modules • 1974-76 sales and service of professional STUDER equipment at Studer Revox South Africa, Pty, Johannesburg • Joined Studer International AG in 1976 after his return to Europe as Product Engineer for Mixing Consoles and Studio Systems • As Sales Engineer responsible for the private sector of the Swiss market.

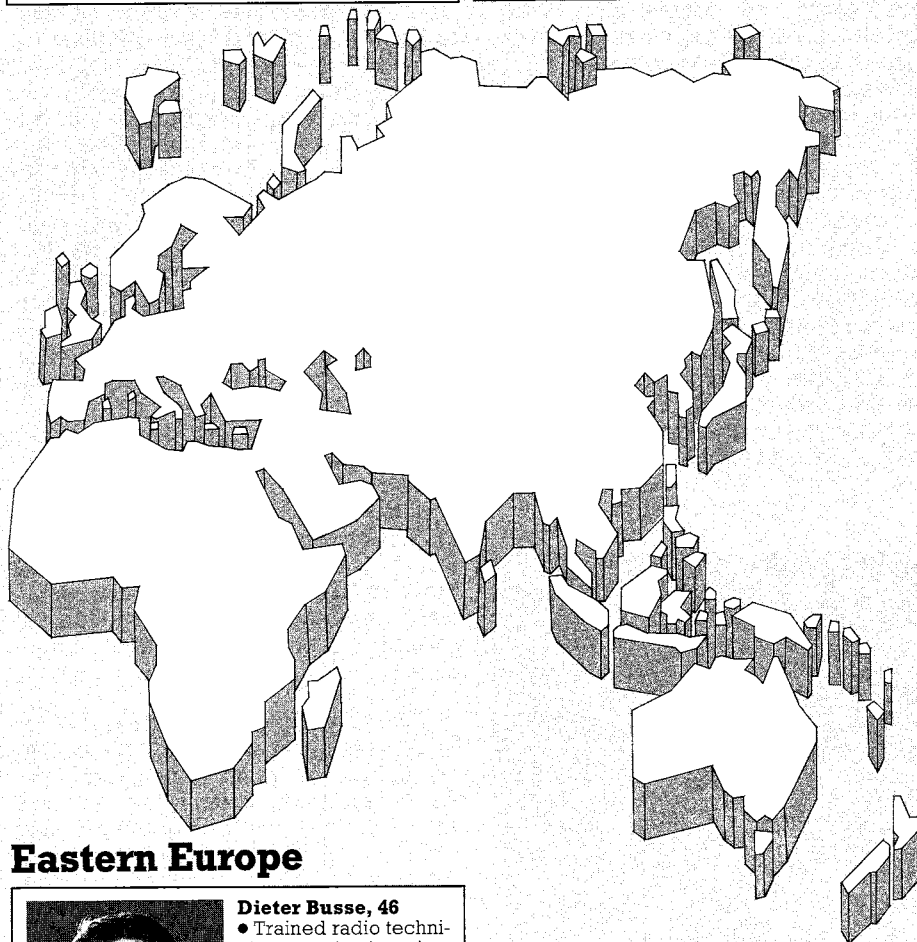

Eastern Europe



Dieter Busse, 46
 • Trained radio technician; practice in various branches of the radio industry • Part-time studies of televisions electronics • 1966 as Service Technician with EMT, sales organisation including distribution of STUDER professional equipment. Service activities for STUDER products in domestic market and abroad. Holds service courses and seminars for technical staff of distributors and clients • 1972 service technician of Studer International AG • 1975 Sales and service activities in Eastern Europe in his responsibility as Area Sales Manager.

Near and Middle East South East Asia

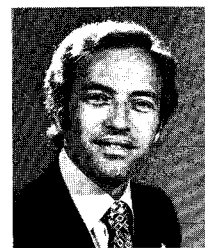

Rolf Breitschmid, 44
 • Trained radio technician; practical work in the field of prof. radio equipment • Studies at the Academy of Nautics, Bremen, Germany; radio officer of the Suisse Atlantique Shipping Line, Lausanne • HF Laboratory assistant, test field work at Albiswerk AG, Zurich; radar electronics engineer at the Department for Military Airfields, Emmen, Switzerland • Systems technician for electronically controlled automatic business machines at Rank Xerox AG, Zurich • Project Engineer for Naval Fire Control Systems (military sales department) at Contraves AG, Zurich • Additional education: Vocational School, Zurich; College of Technology, Hull, England; Management and Marketing School, Zurich; EDP diploma • Since 1976 in the STUDER group; Area Sales Manager at Studer International AG.

Far East Australia/New Zealand Italy



Paul Meisel, 39
 • Four years training in mechanical drafting for high-tension switching systems at Brown Boveri & Cie. AG, Switzerland • Studies of the English language for 8 months, in England • Studies of electrical engineering at the Polytechnic School of Engineering, Windisch, Switzerland; graduated engineer HTL • Joined STUDER in 1972; worked in the test field department; also laboratory work in the development group of magnetic tape recorders • Management course at the Commercial Training College Zurich • 1979 Area Sales Manager at Studer International AG.

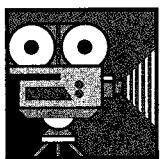

STUDER Part of "Texas-Size" TV Sound

Top Audio Quality

Not long ago, Texas was best known for its wide open spaces, cowboys, oil, money, and a certain absence of modesty among its citizens. But today, thanks to the new TELE-IMAGE facility in Dallas, Texas is best known for state-of-the-art audio in teleproduction along with cowboys, oil, money, etc.

Like most things in Texas, Tele-Image is big (over 32,500 square feet) and expensive (about 6.3 million US Dollars). But even more important than the interior "open spaces" and the money is Tele-Image's commitment to excellence, particularly where audio is concerned.

"Our advanced audio capabilities represent our most aggressive investment," says Tele-Image president Bob Schiff. "We made that investment because we wanted a facility that would lead the market in truly marrying audio and video. We also lead the market in that we are fully equipped for stereo television production."

Planning for future expansion, Tele-Image has room for six video editing

rooms, with three rooms currently on line. But, when it comes to audio, the real showpiece at Tele-Image is the Audio Suite. This room was built and equipped in the true Texas tradition: "Make it big, then fill it with the best."

The stunningly designed audio control room is exceptionally large (600 sq. ft. with 12 ft. average ceiling) to allow natural deep bass response. The spacious layout, along with careful monitor design, also gives the room a large "sweet spot," or optimum listening area. Room design concepts were contributed by Tele-Image staff members, including vice president Chris Nicolaou, audio consultant Chuck Chiles, and audio supervisor Gary French. Acoustic design was entrusted to Russ Berger of the Joiner-Rose Group. Important design innovations include a Reflection Free Zone (RFZ™) ceiling and a quadratic residue diffusion system on the rear wall. The all-cone main monitors are each mounted on a 2000 lb. inertia base with spring suspension for isolation. Essentially, the room is a world-class recording studio within a video facility.

The Tele-Image audio room also offers the computer power of a Solid State Logic 4000 E mixing console with Total Recall, along with a full complement of STUDER tape recorders: A800 24-track, A800 8-track, and A820 TC 2-track. Tele-Image was the first facility in the USA to take delivery on the brand new A820 TC, which features center-track time code capability.

The Tele-Image commitment to quality audio carries over into the edit rooms, each with full stereo capabilities. All three rooms have special acoustic treatments, total sound isolation, and E.M. Long stereo monitors. Video tape machines and computer drives for the edit rooms are housed in a central equipment room to provide noise isolation as well as increased production flexibility. A STUDER A810 TC is featured in Edit A, while audio mixing in Edit C is accomplished with a STUDER 169 console. Additional A800-8 and A810 TC recorders are available for use where needed.

STUDER recorders were selected by Tele-Image after thorough evaluation of all comparable makes and models. Recommendation received from other STUDER users in the teleproduction industry – the "high end" rooms in New York and Los Angeles in particular – were given special consideration, according to audio consultant Chuck Chiles.

"We fully expect the Studers to serve us very well," says Chiles. "We bought the Studers because of their reputation for reliability in demanding applications. Here, they will be under computer control most of the time, and with all the unforgiving things a computer can do to machines, we thought the Studers would hold up much better than the others we looked at. Also, the clients are impressed. Studer machines give us a good 'wow factor'."

With such a superb facility, you might expect Tele-Image to compete with the big video houses on the East and West Coasts for major network productions. But that's not the plan. President Bob Schiff says Tele-Image expects plenty of work from the prosperous local and regional markets of Dallas and the Southwest.





"We're not trying to be another Hollywood," says Chuck Chiles. Why should they bother? All they do in Hollywood is make movies and TV shows about Texas

cowboys, Texas oil, Texas money, skullduggery in Dallas, Texas, etc., etc.

Bruce Borgerson, Nashville

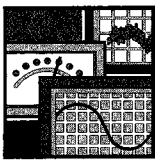

Multiplex Units for Series 900 Consoles

MPX makes Rapid Radio even faster

Radio is a very up-to-the-minute medium because it operates so quickly. In fact, it is probably the fastest reacting medium of all. How different it is from television, which is so much more costly and complex, is especially obvious when reports are being broadcast simultaneously from different venues or when conference circuits are used. Multiplex systems have been developed to make radio fast even when complicated circuits are being used. We want to introduce to you here the STUDER multiplex units which are directly integrated in the 900 series of mixing consoles.

A two-wire circuit is sufficient to transmit a conversation. If, independently of this, the ability to pass on comments or instructions, or to play back the summing programme (live broadcast or recording signal) is required, a further two-wire circuit is needed. As long as only one reporter is broadcasting, this presents no problem.

Any announcement can be transmitted on the return circuit, even immediately before and during a live broadcast. For example, the reporter on the spot can

"cut in" directly because he is also listening in to the broadcast in progress on the return channel. Equally, he can receive instructions while the report is in the progress, such as "please speak closer to the microphone - background noise too loud". If the transmission involves a conference with participants in different locations - all over the country, or even on different continents - the situation is somewhat more complex. In this case the control centre in the broadcasting studio must be able to speak to each O.B. point individually without disturbing the other reporters or participants in the conference. Each of them should be able to listen in to the programme, but without having his own words sent back to him. This drastically reduces the risk of feedback, and the reporter does not always need to use earphones for the return signal - but if he prefers to use them, he will not be disturbed by his own voice. Over long transmission distances, for example via satellite, fluent speech would otherwise be quite impossible owing to the audible delay in hearing one's own words on the return channel.

Any required modulation should, of course, be able to be transmitted via this return channel. The person leading the

discussion and the technician at the main mixing console should be able to pass on specific instructions to individual O.B. points, certain groups of them, or all of them together, without disturbing the broadcast in progress.

Finally, the participants should be able to communicate with each other during the preparatory phase and in interludes (musical "fillers") without disturbing the broadcast in any way. In such phases it should also be possible to add in the broadcast in progress by way of background information. The 1900 Hz calling signal recommended by the EBU should, of course, be able to be transmitted and detected in the input circuits.

Given these specifications, a clear and well-structured operating concept for the multiplex units is very important, since during hectic live transmissions, for example from rapidly changing sports venues, the technician at the main mixing console is hardly likely to have time to consult the operating manual...

The design of the Studer Multiplex Units (MPX) bears all these considerations in mind. The following paragraphs will throw more light on the technical aspects of the MPX broadcasting and master units.

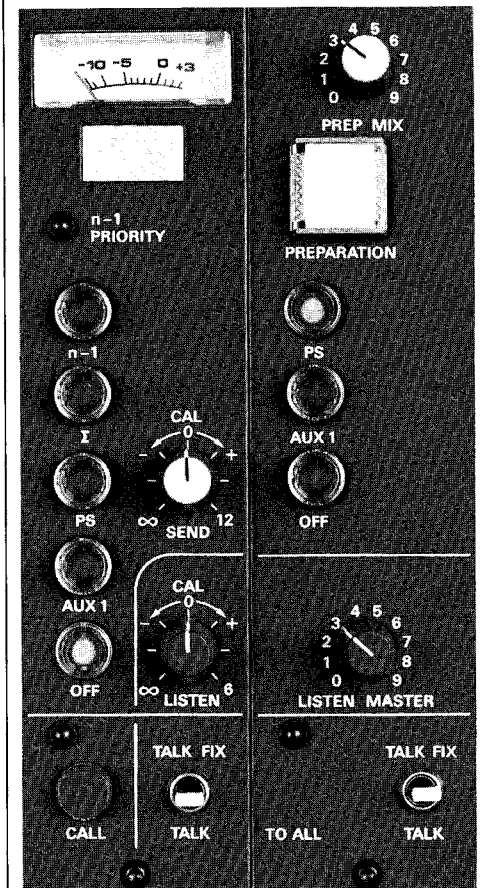

MPX Send Unit

MPX Master Unit

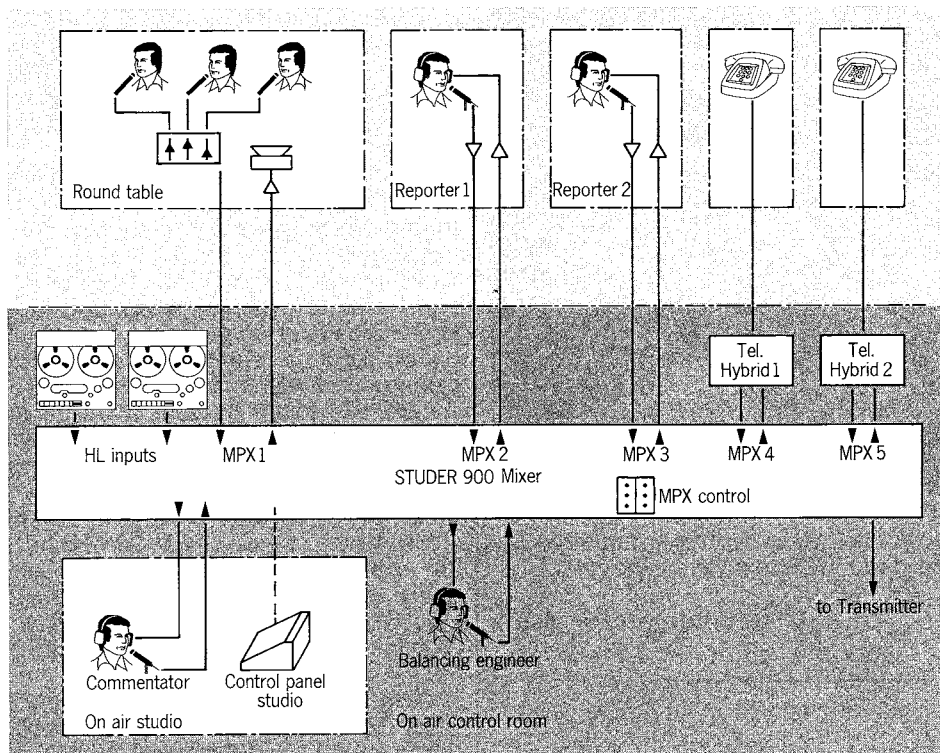

Basic presentation of a MPX circuit.

The input section of a mixing console can be subdivided into three groups:

- 1. Microphone inputs;** includes all input units to which studio microphones are connected.
- 2. Internal high-level sources** process the internal studio sources such as tape machines, record players, cassette and cartridge units.
- 3. External sources.** This group incorporates all input units to which high-level sources located outside the studio are fed. This is where the transmission circuits from all O.B. points and the outputs of the telephone rerecording equipment meet.

Only this last section, intended for outside broadcasts, is equipped with multiplex units. They are accommodated in the sloping part of the console immediately behind the relevant input units.

The **incoming** sound signal is first fed to a 1900 Hz sensor. Calling signals at this – EBU recommended – frequency are detected and light up the call LED as well as actuating a buzzer. The sound signal is corrected in the usual way in the subsequent stereo or mono input unit, levelled by the sliding control, and fed to

the summing bus via the panorama potentiometer.

MPX Send Unit

All functions related to pre-listening, communication with the O.B. point and in particular the return signal are assumed by the multiplex unit.

The type of **return signal** can be selected via 5 push buttons. An auxiliary output of the console (AUX 1) or the output of a programme switch (PS) can be returned. The mono summing signal of all input units is selected with key "Σ".

Key "n-1" also switches the mono summing signal to the output, but its own signal is suppressed by a subtraction circuit. The SEND potentiometer enables the level of the return signal to be adjusted individually; this can be monitored on the level indicator located above it. Certain sources, such as telephone switch-in devices, always require an "n-1" signal during transmission. The associated MPX modules can be programmed so that this signal is automatically connected through when the fader is opened. The "n-1 PRIORITY" LED lights up at the same time.

The operating controls for communicating with the O.B. point are accommo-

dated in the lower part of the module. These include the calling lamp and a push button for transmitting a 1900 Hz calling signal. The TALK command switch (with a hold and an impulse setting) permits talking on the return circuit.

A pre-listening signal can be added in with the LISTEN potentiometer. This signal is interrupted automatically as soon as the sliding fader of the input channel is pulled up.

MPX Master Unit

This incorporates all functions related to the higher multiplex range of the console.

The upper section of this unit contains the control elements of the preparation circuit. The main switch PREP activates an "n-1" circuit which is completely separate from the normal console.

This circuit incorporates all inputs of the multiplex section whose sliding faders are closed. O.B. points which are not connected to the broadcast in progress can thus communicate with each other and discuss their next contribution with the producer in the studio. A selector switch and a potentiometer enable the programme to be added in so that this set of participants, still in the preparatory phase, can also follow the broadcast in progress. The preparation circuit is designed so that the testing function of an input unit is fed back to the transmission mode as soon as the sliding fader of the relevant channel is opened. The LISTEN MASTER potentiometer controls the volume of the pre-listening loudspeaker.

The lower section of the MPX Master Unit also incorporates a command switch which permits simultaneous speech on all the return circuits.

Studio Control Panel

The speaker in the studio also listens in to the pre-listening signal over a loudspeaker. During the broadcast he can listen in to the preparation signal or the broadcasting signal, as he wishes. Instructions from the producer are also added in.

He can speak to each participant individually or to all at once at any time, without this being audible in the broadcast.

The very much simplified block circuit diagram illustrates the different signal levels.

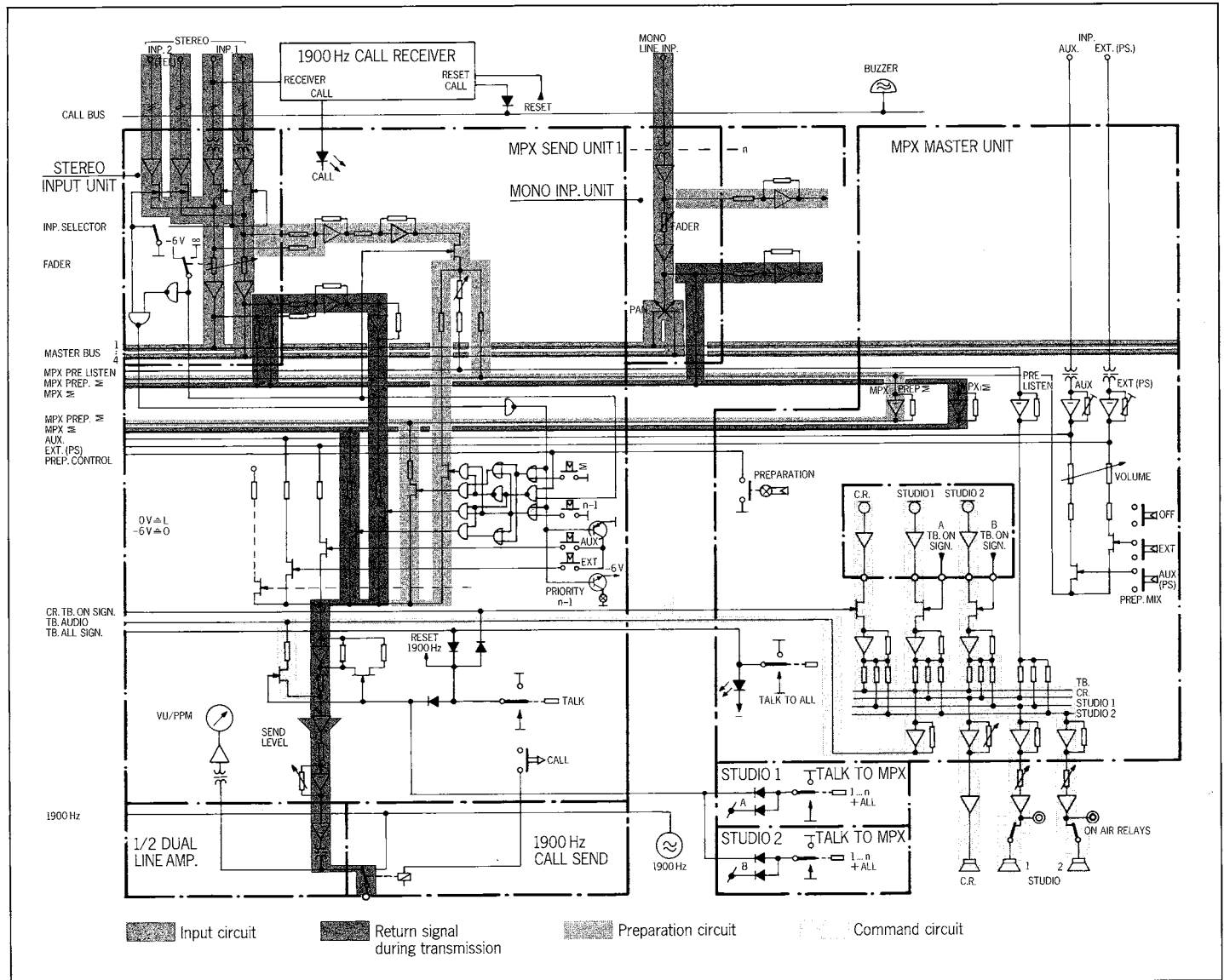

Simplified block diagram for MPX functions.

Hermann Stierli
Marcel Siegenthaler



Agreement with MELTRON extended

Assembly of STUDER B67 in India

Looking back into the past, one is often surprised when realizing that events which seem to have happened just recently, are dating back quite a number of years in fact. The situation concerning our collaboration with MELTRON Maharashtra Electronics Corporation in Bombay seems to bear some resemblance, because it was back in 1980 when we had signed a 5 year agreement for assembly of B67 mono tape recorders. This agreement expired in August of the current year.

In those five years, approximately 700 kits of B67 machines, consisting of all individual mechanical and electrical components, were sent to India for local assembly. Within the scope of the agreement and with growing experience of our Indian partner, it was the intention that an increasing percentage of in India-produced parts should gradually be introduced. From the original kit, which consisted of some 820 parts, about 360 items are now produced or purchased in India, representing a value

of some 27% on the price of the complete kit. The tape recorders assembled under this agreement were intended for one customer only, namely **ALL INDIA RADIO**. By now, the B67 is firmly established within AIR and with an additional requirement for a respectable quantity of recorders, it was our mutual desire to continue the collaboration in the existing manner. The renewed agreement offers the possibility to include other STUDER products, because India is planning to introduce stereo-FM; this

has the logical consequence that there will be a need for stereo tape recorders and mixing consoles as well.

Two gentlemen from MELTRON's management were in Regensdorf recently to discuss the extension and necessary adaptations of our agreement. These talks were held in a pleasant atmosphere, and shared common understanding of the problems associated with such a collaboration which culminated in the signing of an extension for another five years.

At about the same time, two engineers from MELTRON were here in Switzerland to discuss and to clarify several technical questions. During their visit to the STUDER plants in Löffingen, Bonnendorf and Säckingen, they had the opportunity to get some thorough information on our manufacturing methods. We are confident that this will positively add to the good business relationship between STUDER and MELTRON.

Joe Dorner

900 Mixing Console with Extended Module Length

The 900 series mixing console is now available with a new chassis accommodating an additional 40 x 170 mm module between input modules and meter panel.

This space can be used for multi-channel group selectors, additional auxiliary sends, multiplex modules, etc. The example (see photo) shows a 904 mixing console for TV production with facilities for simultaneous "On Air" transmission and multitrack recording. In addition to the 8 groups (selector on the input module), the "In-Line" output selector allows assignment of the input signal (AF or PF) to 12 outputs, switchable 1-12 or 13 to 24 with switchable pan-pot (odd-even) and send level control.

Switchable send-return, the monitoring signal can be fed into the stereo mix bus (with pan-pot) or to the aux 5 bus.

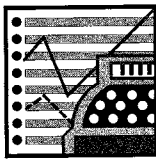

Right on Success

Studer worldwide

Sweden

Sveriges Television

After careful evaluation, Swedish Television selected STUDER Mixing Consoles of the 900 series. Two STUDER 903 consoles will be supplied in December 1985. An order for nine STUDER Time Code Recorders was also placed by the television company.

England

British Broadcasting Corporation (BBC)

BBC were one of the first European broadcasting companies to decide for the new STUDER A820 magnetic tape recording machine. The initial BBC order comprises eight STUDER A820-2 TC VUK for operation at BBC television.

Belgium

Radio Télévision Belge (RTBF)

In the course of replacing certain film/video sound equipment, RTBF has ordered several complete audio post production systems of STUDER make. Two of the new STUDER Audio Editing Systems SC 4008 and one SC 4016 model, as well as 10 STUDER A810-2 TC machines equipped with a special version prelistening head are also part of the order. The system configuration of STUDER facilitates an operational modus as applied in film technique.

Promotion at Studer International

Effective July 1st, 1985, Margrit Meyer has been appointed Deputy General Manager.

In addition to her responsibilities in Sales Administration (please refer to "Who is who" in SWISS SOUND 11/85), she is now second in command and acts on behalf of our General Manager, Mr. Eugen Spörri, in his absence. For questions and decisions of technical nature, Margrit Meyer will be supported by Product Managers Mr. B. Hochstrasser and Mr. H. Stierli.

Our congratulations go to Margrit Meyer for this promotion, combined with our best wishes for continued success in her career.

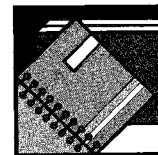

From the printers

10.26.0360	Swiss Sound Special Abu Dhabi (g)
10.26.0370	Swiss Sound Special Abu Dhabi (e)
10.27.0140	A725/A725 QC OI/SI (g/e/f)
10.18.4911	PR99 MKII Leaflet (g)
10.29.0600	B206 Accessory Leaflet (g/e/f)
10.29.0680	External Control Units Accessory Leaflet (g/e/f)
10.29.0690	Cable Accessories Leaflet (g/e/f)
10.29.0700	B202 Accessory Leaflet (g/e/f)
10.30.0230	B215 SI (g/e/f)
10.30.0250	B285/B286 SI (g/e/f)
10.30.0340	B205 OI (g/e/f)
10.30.0440	B215 OI (dutch)
10.30.0470	B285/B286 Mini OI
10.30.0480	B215 Mini OI

PI = Product information
 TI = Technical information
 OI = Operating instructions
 SI = Service instructions
 SD = Set of diagrams

Sets of diagrams, operating and service instructions available at nominal charge.

Please mail your letters to:

SWISS SOUND, STUDER INTERNATIONAL AG
 Althardstrasse 10, CH-8105 Regensdorf
 Phone 01/840 29 60 · Telex 58489 stui ch
 Telefax 01/840 47 37 (CCITT 3/2)

Editors:

Heinz Schiess, Marcel Siegenthaler

Art and production: Lorenz Schneider

Publisher: WILLI STUDER AG,

Althardstrasse 30, CH-8105 Regensdorf

Reprint permitted with reference to

SWISS SOUND (please send a copy to the editor)

Printed in Switzerland by WILLI STUDER AG

10.23.8210 (Ed. 10.85)

For further information please contact

